

ELIX

Smart opening sensor for automated swing doors

User's Guide for software version SW 0100 and higher (refer to tracking label on product)

1. INTENDED USE

The ELIX is a smart opening sensor for automated doors, powered by advanced FMCW technology. The sensor understands movement and adapts its behaviour to the flow of people. It opens the door matching their intention to pass. By analyzing direction and speed, it ensures a smooth and comfortable passage while optimizing every opening. In doing so, it also prevents unnecessary energy loss.

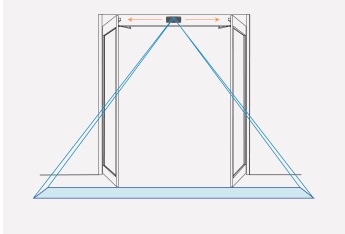

Mounting on swing doors - flexible mounting position.

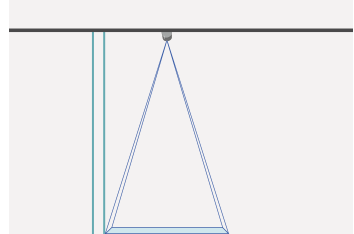

Ceiling mounting in front of a door.

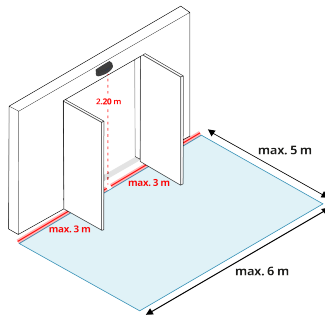

MOVA
INSIDE

- Only trained and qualified personnel may install and setup the sensor.
- The sensor cannot be used for purposes other than its intended use.
- The installer must read, understand and follow the instructions given in this user guide.
- The manufacturer of the door system incorporating the sensor is responsible for compliance of the system to applicable national and international regulations and safety standards.
- Improper installation can result in improper sensor operation.
- The manufacturer of the sensor cannot be held responsible for injury or damage resulting from incorrect use, installation or inappropriate adjustment of the sensor.

2. TIPS

✘	✘	✘
Avoid vibrations, condensation, sudden and extreme temperature changes.	Do not cover the sensor.	Avoid moving objects in the detection field and metallic parts in the sensor's close environment that may obstruct the detection field.

3. DESCRIPTION

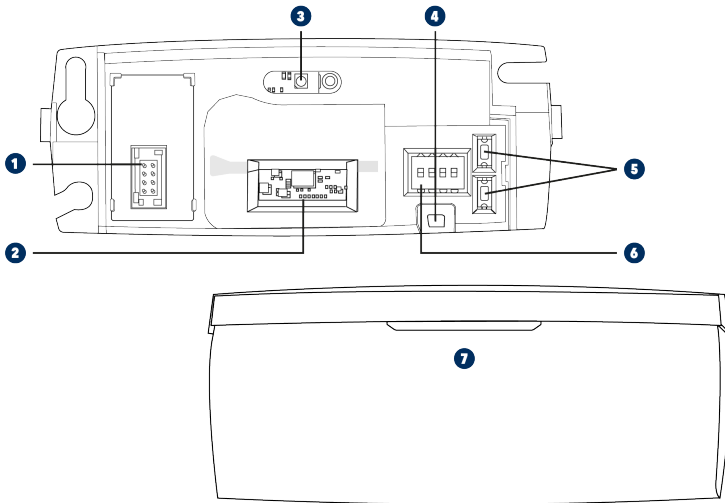

- 1** Main connector
- 2** Antenna
- 3** LED 1
- 4** LED 2*
- 5** Push buttons
- 6** DIP-Switch
- 7** Cover

LED SIGNALS

- Opening
- Green LED blinks
- Red LED blinks
- LED blinks red-green
- Bluetooth®
- Orange LED blinks x times
- LED is off

* LED 2 turns off automatically after 30 minutes of operation. It supports the installer in clearly viewing the LED feedback for as long as the external cover has not yet been fitted.

4. MOUNTING ON DOOR

Remove the cover

When holding the sensor in your hands, remove the external cover by inserting a screwdriver into the left or right notch located on the backside of the sensor. Use the screwdriver as a lever to lift off the cover.



NOTE

Once the sensor is mounted on the door, remove the cover by inserting a screwdriver on the left or right side notch of the sensor and twist it to remove the cover.

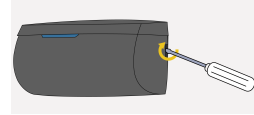
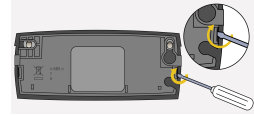

1. Apply the mounting template. Drill 1 hole (Ø 5 - 7 mm Ø 1/4") for the cable and pull it through. Drill 2 holes (Ø 3 mm Ø 1/8") for the screws.



2. Plug the connector accordingly or use dedicated retrofit interface to connect any existing cable.

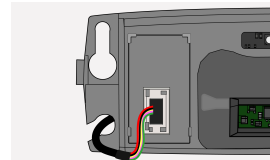

3. First, position the cable according to the hole in the wall. To prevent the cable from being crushed, route it through the space at the backside of the sensor. Then, firmly fix the sensor in place.



5. CONNECTING THE SENSOR



Power supply



OUT 1: Opening



OUT 2*



OUT 3*

*In the present version of ELIX, only Output 1 is functional and dedicated to door opening. Outputs 2 and 3 are not assigned and are reserved for additional functions in future versions.

6. INSTALLATION VIA APP

It is recommended to use the ELIX mobile app for installation, as it provides access to all sensor settings and ensures the easiest and most complete setup — including advanced options such as detection **field dimensions**, **exclusion area configuration**, and **the full range of cross-traffic filter levels**.

Scan the QR code or open the following link to download the mobile application and install it.

<https://play.google.com/store/apps/details?id=com.beasensors.elix>

<https://apps.apple.com/app/elix-set/id6745556056>

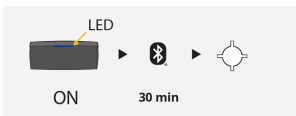

The white Bluetooth® LED blinks slowly.
At power ON or after a power cycle, the Bluetooth® keeps activated 30 minutes after last use and then turns off automatically.

Alternatively, push 1x on the upper white button or the lower black button to reactivate Bluetooth®.



Open the ELIX mobile app and connect it to the sensor. During pairing, the Bluetooth® LED blinks quickly.

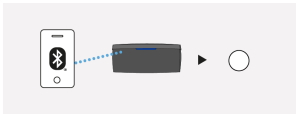

Once paired, the white Bluetooth® LED is on.

The Bluetooth® word mark and logos are registered trademarks owned by Bluetooth SIG, Inc. and any use of such marks by BEA sa is under license. Other trademarks and trade names are those of their respective owners.

Home

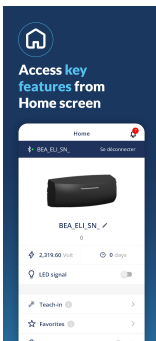

Teach-in

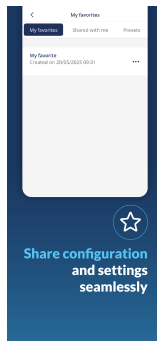

Settings

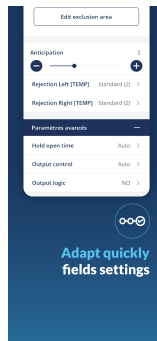

Viewer



Diagnostic

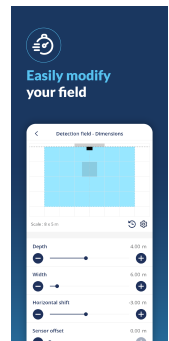

7. INSTALLATION VIA SENSOR INTERFACE

Please note that only basic user settings are available via the sensor interface. For access to the full range of parameters, use the ELIX mobile app (see page 5).

DIP-SWITCH

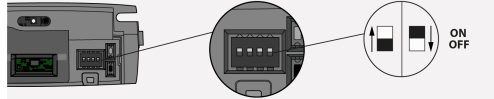

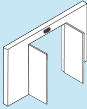
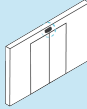
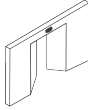
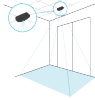
DIP 1	DIP 2	DIP 3	DIP 4
Mounting side	Mounting type	Cross traffic filter level - left	Cross traffic filter level - right
ON* OPENING SIDE - i.e., the side of the moving door leaves 	ON* ABOVE THE DOOR - i.e., the sensor's antenna is facing straight down 	ON* MEDIUM - some left side parallel pedestrian flow is filtered out	ON* MEDIUM - some right side parallel pedestrian flow is filtered out
OFF CLOSING SIDE - i.e., the side opposite the moving door leaves 	OFF CEILING MOUNTING - i.e., the sensor's antenna is facing forward into the detection field 	OFF HIGH - most left side parallel pedestrian flow is filtered out	OFF HIGH - most right side parallel pedestrian flow is filtered out
<i>*Factory Values</i>			
After changing a DIP-switch, the LED blinks orange. A long push on the upper white or lower black button confirms the setting.			

SETTING VIA BUTTON:

1) Opening trigger level:



Push 1x on upper white button to **increase opening trigger level.**
 Higher levels trigger the door earlier at the same approach speed.



Push 1x on lower black button to **decrease opening trigger level.**
 Lower levels trigger the door later at the same approach speed.

2) Reset to Factory Values:

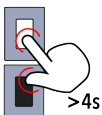

Long push (> 4s) on both buttons simultaneously to Reset to **Factory Values.**

TEACH-IN VIA BUTTON

1. Environment teach-in

- Press the lower black push button 2s to launch the teach-in. The LED starts blinking red-green.

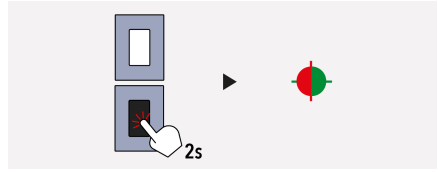

- Please stop the traffic, step back approximately 3 meters, and stand still while the sensor is initializing and closing the door.

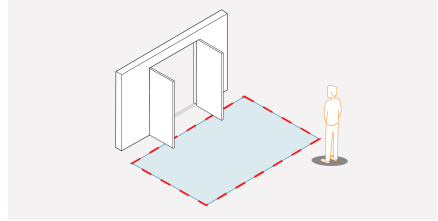

- The LED starts blinking green slowly. Please walk towards the center of the doorway and stop about one meter in front of the door. The LED starts blinking red. You can leave your position.

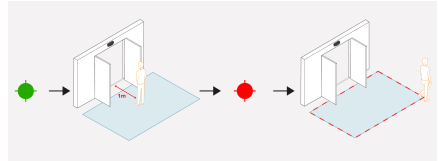

2. Door teach-in



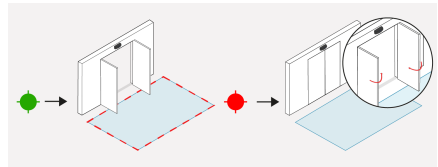



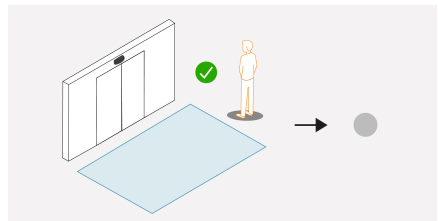

- The LED starts blinking green slowly. Please stand still and make sure the detection field is clear. The LED starts blinking red. Please wait while the door is opening and closing.



- Once the door is completely closed again and the LED is off, the teach-in is completed.





8. TROUBLESHOOTING

LED	Status	Explanation / Solution
	The door remains closed. The LED stays off.	<p>The sensor power is off. Check the wiring and the power supply.</p> <p>The door control setting is set to value "closed". Change the door control setting to "Auto" via mobile app > Settings > Advanced settings.</p>
	The door does not react as expected. The blue LED lights up when door is closed.	<p>Improper output configuration on the sensor. Change the output configuration setting on each sensor connected to the door operator via mobile app > Settings > Advanced settings.</p>
	The door opens and closes constantly. The blue LED lights up regularly.	<p>The sensor is disturbed by the door motion or vibrations caused by the door motion.</p> <ol style="list-style-type: none"> 1. Make sure the sensor is fixed properly. 2. Launch a new teach-in. If mounted on closing side and using the mobile app, choose opening side during the teach-in. 3. Check on the viewer in the mobile app at which location a false detection is created. Create an exclusion area if needed or adjust the detection field dimensions.
	The door opens for no apparent reason. The blue LED lights up.	<p>In airlock vestibules, the sensor detects the movement of the opposite door. Adjust the detection field dimensions via mobile app.</p>
	The Orange LED is on permanently.	<p>The sensor encounters a memory problem. Replace the sensor.</p>
	The orange LED blinks 1x.	<p>The sensor signals an internal fault. Cut and restore power supply. If the LED blinks again, replace the sensor.</p>
	The Orange LED blinks 2x.	<p>Power supply is out of limit.</p> <ol style="list-style-type: none"> 1. Check power supply. 2. Reduce the cable length or change the cable. <p>Internal temperature is too high. Protect the sensor from heat source (sun, hot, air...).</p>
	The door does not react as expected. The Orange LED blinks 3x.	<p>Internal communication error. Cut and restore power supply. If the LED blinks again, replace sensor.</p>
	The Orange LED blinks 5x.	<p>Teach-in error. Launch a new teach-in via mobile app or via button (see page 7).</p>

9. TECHNICAL SPECIFICATIONS

Technology	FMCW, Mowa inside (microwave)
Transmitter frequency	60 GHz
Transmitter radiated power	< 20 dBm EIRP
Transmitter power density	< 5 mW/cm ²
Detection mode	Motion
Max. detection range	6m x 5m The effective detection range depends on the mounting height and mounting position of the sensor.
Supply voltage	12V to 24V AC +/- 10% (50 - 60 Hz) ; 12V to 24V DC +30% / -10%
Max Power consumption	< 1 W
Output:	Solid-state relay (free of polarity)
Max. switching voltage	30V AC / 42V DC
Max. switching current	100mA (resistive)
Mounting Height	From 1.8 m to 4 m
Degree of protection	IP54 (IEC/EN 60529)
Temperature range	From -20 °C to + 55 °C
Dimensions	120 mm (L) × 50 mm (H) × 50 mm (W)
Material	ABS/ASA/PC - Black - Aluminium - White
Weight	120g
Cable length	2.5m
Bluetooth®	Operating bandwidth: 2402 MHz – 2480 MHz Maximum transmitted power: 12 dBm

10. CONFORMITY

BEA hereby declares that this product is in compliance with European legislation, 2014/53/EU (RED) and 2011/65/EU (RoHS). The complete declaration of conformity is available on our website.	
This product should be disposed of separately from unsorted municipal waste.	



WWW.BEASENSORS.COM

BEA SA | LIEGE Science Park | ALLÉE DES NOISETIERS 5 - 4031 ANGLEUR [BELGIUM] | T +32 4 361 65 65
| F +32 4 361 28 58 | info-eu@beasensors.com | WWW.BEASENSORS.COM

A **Halma** company

Manufactured by: BEA SA - LIEGE Science Park - Allée des Noisetiers 5 - 4031 Angleur - Belgium - T +32 4 3616565 - F +32 4 3612858 - info-eu@beasensors.com - www.beasensors.com

PLEASE KEEP FOR FURTHER USE - DESIGNED FOR COLOUR PRINTING