



MICROCELL ONE, TWO, THREE USER'S GUIDE

POSITION OF DIP-SWITCH #2 : MICROCELL ONE AND TWO

MICROCELL ONE

Dip-Switch #2	Power OFF	Power ON	Detection	AC/DC Supply loss	Cable break	Cable break
OFF				-	-	+
ON				+	+	-

In the event of disappearance of the supply voltage or cable breakage between the door operator and the Microcell box :
(+) : the fault is detected - (-) : the fault is not detected

Important note : when the barrier is used for safety purposes, it is recommended that the relay output is wired between terminals 3 and 4 and Dip-Switch 2 is placed in the ON position. In this way, in the event of a connection cable breakage or a power supply fault, the door operator will receive a signal and the door will be held in the open position.

MICROCELL TWO

Dip-Switch #2	Power OFF	Power ON	Detection	AC/DC Supply loss	Cable break	Cable break
OFF				+	-	+
ON				-	+	-

In the event of disappearance of the supply voltage or cable breakage between the door operator and the Microcell box :
(+) : the fault is detected - (-) : the fault is not detected

Important note : when the barrier is used for safety purposes, it is recommended that the relay output is wired between terminals 3 and 5 and Dip-Switch 2 is placed in the OFF position. In this way, in the event of a connection cable breakage or a power supply fault, the door operator will receive a signal and the door will be held in the open position.

POSITION OF THE DIP-SWITCHES #1 AND #2 : MICROCELL THREE

Dip-Switch #1	Dip-Switch #2	Output	Output voltage Barrier established	Output voltage Barrier interrupted	Supply loss	Cable break
OFF	OFF	NPN/N	OV	*	+	+
OFF	ON	NPN/R	*	OV	-	-
ON	OFF	PNP/N	Vcc (**)	*	+	+
ON	ON	PNP/R	*	Vcc (**)	-	-

* : Output voltage at the operator terminals

** : Vcc : supply voltage applied to the board

In the event of disappearance of the supply voltage or a cable breakage between the door operator and the Microcell box :
(+) : the fault is detected - (-) : the fault is not detected

TECHNICAL SPECIFICATIONS

Technology active infrared, microprocessor
Mounting height 0.2 m minimum above the ground
Distance between beams 0.3 m minimum (crossed beams)
Distance with respect to the plane of the doors 2 cm
Minimum range 1 m
Maximum range 5 m - for minimum height of 0.2 m

Beam aperture half-angle 8°
Detection mode presence (by interruption of the beam)

Response time
 • transistor output (Microcell Three) ≤ 10 ms (beam set-up or cut-off)
 • relay output (Microcell One and Two) ≤ 40 ms

Hold time
 • relay output (Microcell One and Two) 300 ms

Supply voltage (Microcell One and Two) 12-24 V AC ±10%
 12-24 V DC -5/+30%
 (Microcell Three) 12-24 V DC -5/+20%

Power consumption

• control box < 100 mA
 • monitoring signals < 10 mA

Output (Microcell One and Two) 1 or 2 relays (voltage-free contact)
 • contact max. voltage 50 V DC / 50 V AC
 • maximum current 1 A (resistive)
 • maximum switching power 30 W (DC) / 50 VA (AC)
Output (Microcell Three) open-collector transistor NPN or PNP selectable

• relay contact ratings (max. voltage) 30 V DC
 • maximum current 20 mA
 • voltage drop < 2 V at 20 mA

Signalling 1 LED per barrier in the control box
Adjustments (by dip-switch - Microcell One and Two) single/double barrier standard/inverted outputs reduced/nominal range test position

Adjustments (by dip-switch - Microcell Three) NPN/PNP outputs normal/inverted outputs reduced range B/nominal range B reduced range A/nominal range A -20°C to +55°C

Temperature range

Immunity
 • sunlight 75,000 lux
 • incandescent lamp 25,000 lux at an angle of 8°
 • electrical and radiofrequency interference in accordance with EMC 2004/108/EC

Detection head sealing IP 65 (DIN 40050)

Dimensions
 • detection heads body : 10 mm (embedded length) x 12.4 mm (diameter)
 collar : diameter 15.6 mm
 94 mm (L) x 52 mm (W) x 28 mm (H)
 5 m (10 m as an option)

Control box

• control box 0.140 Kg (5 m) / 0.270 kg (10 m)
Cable length
 • emitter 0.140 Kg (5 m) / 0.270 kg (10 m)
 • receiver 0.060 Kg

Housing material

ABS blue transparent

Cables colour (heads)

• receiver green/black or black/blue
 • emitter yellow/black or grey/blue

Cables colour

• receiver green or black
 • emitter yellow or grey

DETECTOR DESCRIPTION

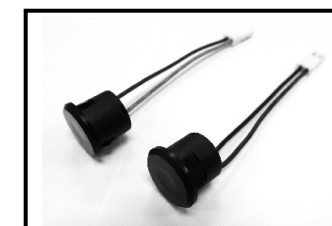

Microcell One
Microcell Two
Microcell Three

barrier composed of cylindrical heads which can be pulled out, with a 5 m cable and a control box fitted with a relay
 barrier composed of cylindrical heads which can be pulled out, with a 5 m cable and a control box fitted with two relays
 barrier composed of cylindrical heads which can be pulled out, with a 5 m cable and a control box which can be monitored, with no relay, with an output transistor. TÜV approved.

MMA

surface mounting accessory

NOTE

- For a single barrier, the name of the product is followed by the index S for "single" (e.g. : Microcell One - S)
- For a double barrier, the name of the product is followed by the index D for "double" (e.g. : Microcell One - D)
- A 10 m cable is provided as an option. In this case, the name of the product is followed by an index L (e.g. : Microcell One - SL)

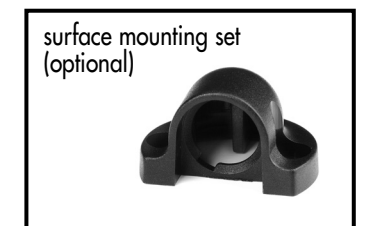
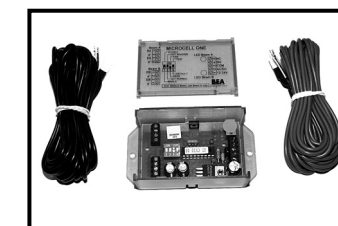

TOOLS

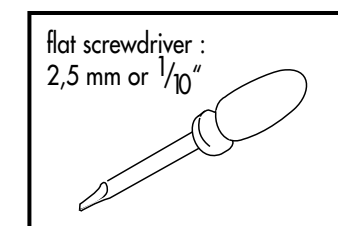
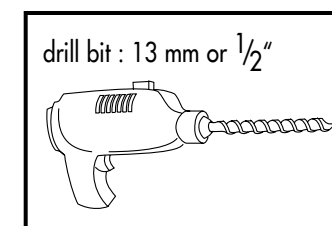

TROUBLESHOOTING

The control unit is fitted with two LEDs, one for each barrier

- when the two LEDs are off, the barrier is established;
- if one of the two LEDs is lit, the corresponding barrier is interrupted;
- if neither of the two LEDs can be lit, there is a power supply fault.

When the assembly is not complete and the LEDs are visible, it is convenient to make use of this indication to carry out alignment of the heads.

SYMPTOMS	PROBABLE CAUSES	CORRECTIVE ACTIONS
LED B is permanently lit	Faulty connection	a. Check the connection of the emitter and receiver b. Check whether Dip-Switch 1 is in the OFF position (for the single barrier)
LED A and/or LED B is permanently lit	Faulty connection Faulty alignment Incorrect power supply	a. Check the connection of the emitter and receiver b. Check the positions of the Dip-Switch c. Check using a voltmeter that the supply voltage is present d. Check the alignment of the emitter and receiver
The LEDs are working, but the door does not respond	Faulty connection of the output relay/transistor	a. Check the connection of the output relay/transistor b. Check whether the Dip-Switches 1 and 2 are configured correctly

Other sources of malfunction

Checking the alignment of the emitter and receiver : a tolerance of 2 x 8° is normally possible; check that the range is not excessive (10 metres maximum)

Checking the distance to the ground of the lower barrier : 20 cm minimum

When there are two barriers, check that the two barriers are correctly at least 30 cm apart

When there are two barriers, check if they are correctly crossed : the emitter of one barrier and the receiver of the other barrier must be situated in the same upright; check if the cabling has correctly associated an emitter with the receiver opposite it

DIMENSIONS

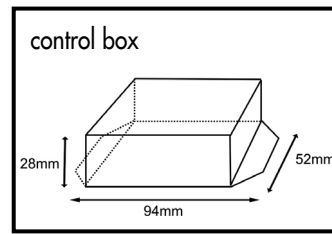
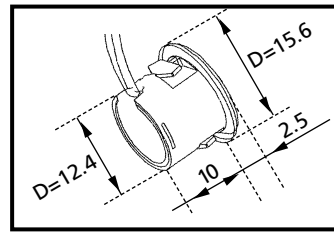

INSTALLATION

SINGLE BARRIER

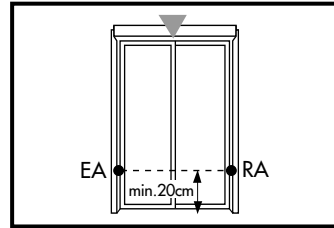

- Choose an installation height.
- Make a mark.
- Make sure that the barrier is at least 20 cm away from the ground.

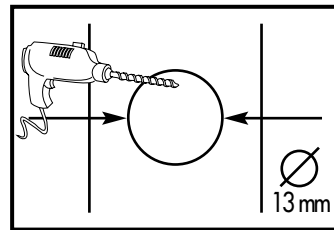

- Drill a 13 mm (or 1/2") hole in each door upright.

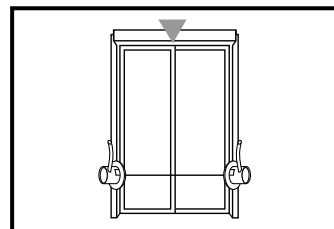

- Slide the heads and cables into the profiled sections.

- Fix the control unit, securing it using the double-sided self-adhesive provided.

- Slip the heat shrink tube on the wire
- Connect the heads and the wire
- Place the heat shrink tube on the wire

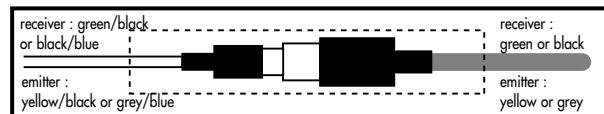

- Heat the tube with a lighter until it suits the shape of the connector (! do not damage the wires)

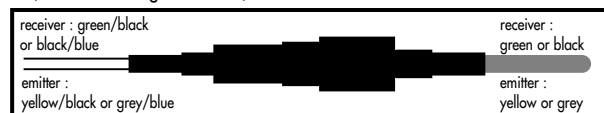

DOUBLE BARRIER

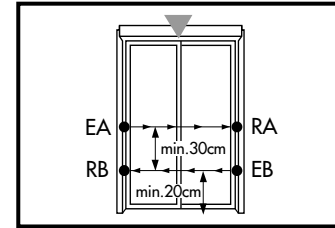

- Choose the two installation heights.
- Make sure that the two barriers are at least 30 cm apart.
- Make a mark.
- Make sure that the barrier is at least 20 cm away from the ground.

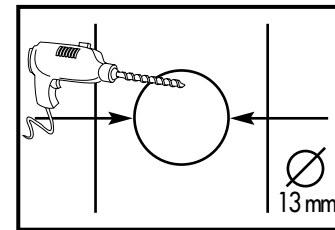

- Drill a 13 mm (or 1/2") hole in each door upright.

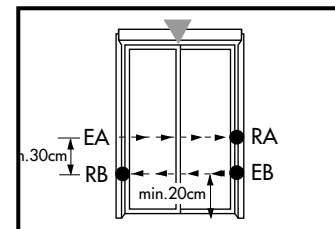

- Slide the heads and cables into the profiled sections.
- Make sure to reverse the direction of propagation of the beams by sliding one emitter AND one receiver into each upright.
- Check that a receiver is correctly situated opposite each emitter.

- Fix the control unit, securing it using the double-sided self-adhesive provided.

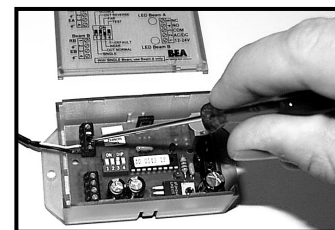

- Connect on the A entries (when it concerns a single beam).

CONNECTION



(*) configuration of the control signals

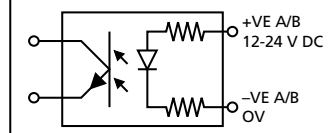

MICROCELL ONE AND TWO

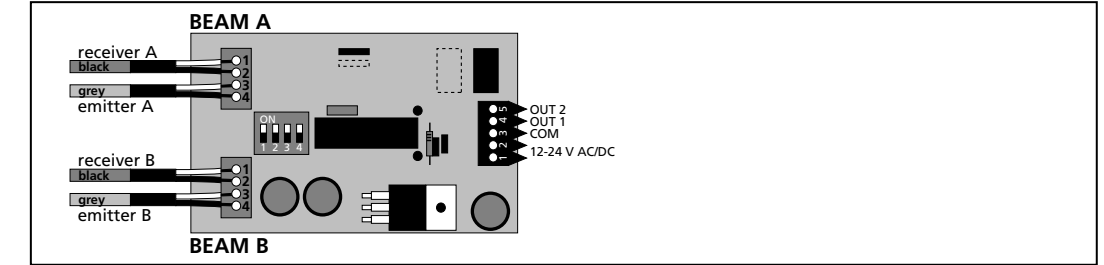

MICROCELL THREE

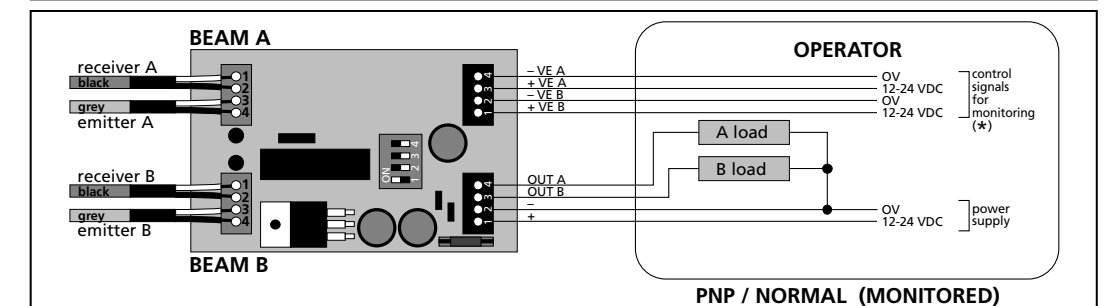
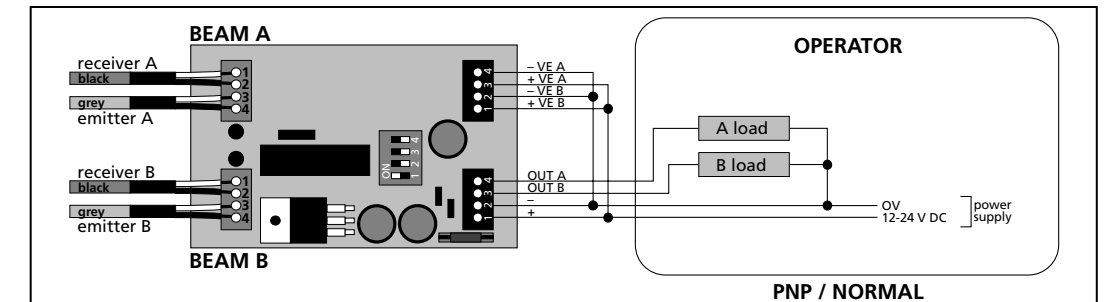
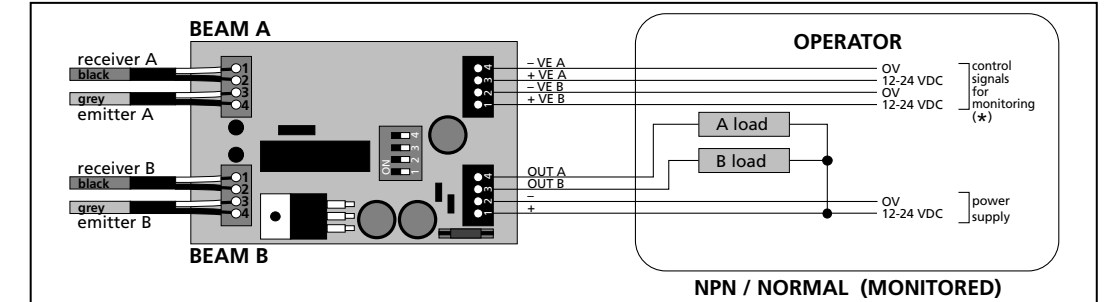
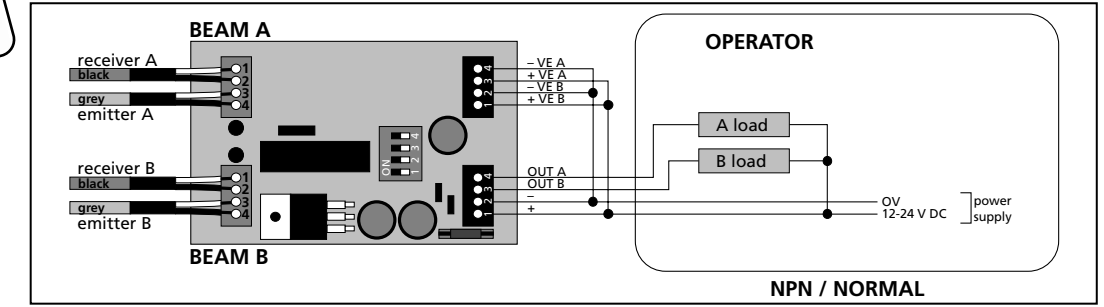

- According to the German safety standards, the door operator must perform periodical test of the Microcell Three through the use of the control signals

CONFIGURATION

POSITION OF THE DIP-SWITCHES



- The configuration mode is set up on the basis of the position of the following 4 dip-switches for the Microcell One and Two models :

	1	2	3	4
▲ ON	Double barrier	Inverted outputs	Normal range (3 m < d < 10 m) *Heads A & B	(Test)
▼ OFF	Single barrier	Normal outputs	Reduced range (1 m < d < 3 m)*Heads A & B	Normal

- The configuration mode is set up on the basis of the position of the following 4 dip-switches for the Microcell Three model :

	1	2	3	4
▲ ON	PNP outputs	Inverted outputs	Normal range Head B	Normal range Head A
▼ OFF	NPN outputs	Normal outputs	Reduced range Head B	Reduced range Head A

Caution, the min. installing height depends on the requested range

- *3 m < d < 5 m if the distance between the beam and the ground is greater than 0.2 m
- 3 m < d < 10 m if the distance between the beam and the ground is greater than 0.4 m